

# A Comparison of System Dynamics and Agent-Based Simulation Applied to the Study of Cellular Receptor Dynamics

Wayne W. Wakeland  
Systems Science Ph.D. Program  
Portland State University  
wakeland@pdx.edu

Louis M. Macovsky  
Dynamic BioSystems, LLC  
DynBioSys@aol.com

Edward J. Gallaher  
Behavioral Neuroscience, Pharmacology and Physiology  
Oregon Health & Science University  
gallaher@ohsu.edu

C. Athena Aktipis  
Department of Psychology  
University of Pennsylvania  
aktipis@psych.upenn.edu

## Abstract

*Cellular receptor dynamics are often analyzed using differential equations, making system dynamics (SD) a candidate methodology. In some cases it may be useful to model the phenomena at the biomolecular level, especially when concentrations and reaction probabilities are low and might lead to unexpected behavior modes. In such cases, agent-based simulation (ABS) may be useful. We show the application of both SD and ABS to simulate non-equilibrium ligand-receptor dynamics over a broad range of concentrations, where the probability of interaction varies from low to very low. Both approaches offer much to the researcher and are complementary. We did not find a clear demarcation indicating when one paradigm or the other would be strongly preferred, although SD is an obvious choice when studying systems at a high level of aggregation and abstraction, and ABS is well suited to studying phenomena at the level of individual receptors and molecules.*

## 1. Introduction

This paper responds to the call by Scholl [1] for cross-study and joint research into agent-based simulation (ABS) and system dynamics (SD) modeling. We contrast these two approaches in the context of modeling cellular receptor dynamics.

We are aware of at least three fundamentally different simulation paradigms that might be useful for improving understanding of receptor dynamics: 1) SD modeling (cf. [2]), which is differential equation

based; 2) traditional stochastic, discrete time, discrete entity Monte Carlo simulation (cf. [3]); and 3) ABS (cf. [4]). Each paradigm has strengths and limitations. For example, SD is particularly well suited to studying systems containing a complex web of feedback loops, while discrete system simulation is preferred when the system contains a high degree of uncertainty. A key strength of ABS is its ability to incorporate spatial as well as probabilistic aspects of the system.

This paper contrasts two of these paradigms, SD and ABS, in terms of their ability to increase understanding and inform research into the dynamics of cellular receptors. Of particular interest is the way in which these two paradigms may help to generate complementary insights and increase the researcher's understanding of the dynamics of systems and processes. This comparison considers the overall approach, the underlying mathematics and analysis, the ease with which results can be communicated to others, research relevance, and educational potential.

As mentioned above, SD is based on ordinary differential equations and their numerical solution over time. The governing rate equations for the system are developed, parameters are estimated, and the time trajectories of the variables of interest are computed and displayed. SD is a mature methodology that has been applied in biomedical applications (cf. [5][6]). Our background includes the application of SD to biomedical systems, including pharmacokinetics [7][8], epidemiological analysis, and non-equilibrium receptor binding.

In ABS, the properties of the system emerge from relatively simple rules governing the interactions of independent agents located on a spatial grid [9]. This

paradigm originated in the field of biology, where research into computer algorithms was being carried out for the purpose of creating “artificial life.” In recent years, software has become available to make it easier to implement these algorithms and portray the results graphically. Simple versions of the software, such as StarLogo [10][11] are restricted to two-dimensional models, although the concepts are easily generalized to three dimensions.

For our comparison of SD and ABS, the application area will be the study of non-equilibrium binding of receptors on the surface of a cell in the presence of different concentrations and types of agonists and antagonists (cf. [12]). Most of the research on receptors has been carried out from an equilibrium perspective, but recently attention has shifted to the behavior over time for the various reactions. Both SD modeling and ABS facilitate such analysis. We will focus specifically on the analysis of positive and negative cooperative binding exhibited by the divalent insulin receptor under various experimental conditions. A recently published differential equation based model for these dynamics [13] provided the necessary details.

Motivating our interest in this area is the fact that equilibrium-binding experiments are expensive and we believe that simulation may contribute to the design and interpretation of more efficient experiments. Most researchers report only the final equilibrium parameters,  $K_D$  and  $B_{max}$ , and not the forward and reverse time constants for the reactions. To carry out equilibrium-binding experiments, the biological material must be isolated, expensive radioactive ligands obtained, and pilot experiments conducted to confirm the viability of the material over the time horizon of the experiment and to determine the concentration range and how long the equilibration process takes. Unfortunately, experimental researchers typically do not obtain transient data from their experiments, perhaps due to logistical difficulties or because they do not see any good reason to do so. Yet, without these time constants, it is difficult to develop credible dynamic computer models of these important processes. We believe that the availability of compelling and useful simulation models might influence researchers to capture this additional data.

To provide a specific context for comparing SD and ABS, we reviewed several biomedical papers that presented relevant time-course data and/or models, including receptor biosynthesis and degradation [14], glucose transporter mechanisms [15], and insulin receptor dynamics [13]. After creating initial exploratory models, we selected the Wanant and Quon paper on insulin receptor dynamics as the basis for comparison. The primary advantages of this paper were that the authors provided their parameter values

and differential equations, and also developed the complexity of the model in a progressive fashion.

## 2. Background

Many cellular processes maintain some form of relative equilibrium between multiple states of a fixed amount of cellular component. Over time, the total amount of the cellular component remains constant for all practical purposes, but is reversibly converted between two states, {A} and {B}, as shown in Figure 1.



**Figure 1. Two states, {A} and {B}**

For example, in the presence of soluble ligands (small molecules such as drugs and hormones), membrane-bound receptors exist in equilibrium between the unbound state {A} and the bound state {B} [16]. Normally inactive enzymes {A} are activated by phosphorylation (to {B}), and inactivated again by hydrolysis of the phosphate bond (back to {A}) [17]. Drugs may be found in equilibrium between water {A} and lipid {B} phases, depending on their oil/water partition coefficients [18] [19].

Ligand-receptor (LR) binding is among the most important of biological mechanisms. The binding process is second order and depends on ligand concentration, receptor concentration, and a forward rate constant ( $k1\_f$ ;  $1/\text{mol}^2\text{-time}$ ). Receptor concentrations are usually normalized to 1 (or 100%), and  $k1\_f$  simplifies to  $1/\text{mol}\text{-time}$ , dependent only on ligand concentration. In the body, ligand concentrations vary over time and from one location to the next. In the laboratory, however, ligand concentrations are often held constant during LR binding experiments. Under these conditions, the *effective* forward rate constant thus simplifies further, carrying the familiar units of a first-order process:

$$k1\_f\_EFF = (1/\text{mol}\text{-time}) \times \text{ligand (mol)} = 1/\text{time} \quad (1)$$

Given the assumption of constant ligand concentration, binding can be described as shown below, and binding decreases as unbound receptor R is depleted.

$$(\text{LR\_associations}/\text{time}) = R \cdot k1\_f\_EFF \quad (2)$$

The LR complex also dissociates spontaneously, again following first-order decay kinetics:

$$k1\_r = 1/\text{time} \quad (3)$$

$$\text{LR\_dissociations/time} = \text{LR} \cdot k_{1\_r} \quad (4)$$

In contrast to binding, dissociations *increase* over time as the LR concentration rises. Taken together, the binding fraction  $\text{LR}/(\text{R\_total})$  approaches an asymptote as the forward and reverse rates equalize. The asymptote depends on the concentration of the ligand, whereas the amount of time required to reach the asymptote depends on the rate constants.

The Michaelis-Menten equation describes the binding saturation as a function of ligand concentration L:

$$\text{Bound R} = ((\text{Total R}) * L) / (K_D + L) \quad (5)$$

$K_D$  (moles/l) is the concentration of L that leads to half-maximal binding, as can be seen by  $(L)/(K_D + L)$  in the above equation. The concentration  $K_D$  can also be shown to equal  $k_{1\_r}/k_{1\_f}$ .

Binding experiments are typically conducted with a series of incubation tubes containing fixed receptor concentrations and with ligand concentrations that remain fixed within each tube, but which increase progressively from one tube to the next. Pilot studies are used to determine how long the cultures must be allowed to incubate before measuring the amount of bound ligand in each tube.

Within each tube, binding occurs over time as an inverted exponential process. When plotted for a series of concentrations, receptor saturation (0-1) as a function of ligand concentration resembles a rectangular hyperbola. These data are usually plotted on a log-concentration scale to produce a dose-response curve that is often referred to as a sigmoid dose-response curve. The midpoint of the curve (i.e., the concentration that half-saturates the receptor population) is known as  $K_D$  and is widely reported as a measure of ligand-receptor affinity. Typical values range from  $1e-12$  mol (picomolar) to  $1e-6$  mol (micromolar), with smaller numbers indicating greater affinity. Log curves are used because these widely varying concentrations preclude the use of a linear scale on the X-axis.  $K_D$  can be readily determined and compared for different ligands by visual inspection of such graphs.

Another common representation of these same data is known as the Scatchard plot. The ratio of bound LR to the free ligand concentration is plotted on the ordinate, against the bound LR on the abscissa. In the case of a single species of receptor in the incubation tube, the Scatchard plot yields a straight line with slope =  $-1/K_D$  (steeper slope indicates higher affinity), and the x-intercept indicates the maximum number of receptors bound ( $B_{\text{max}}$ ). Since the actual number of receptors is generally unknown,

relative  $B_{\text{max}}$  is generally reported as receptor density per mg protein.

Biological preparations are often quite complex. Incubation tubes may contain two or more types of receptors that interact with the same ligand, each with its own distinct rate constant. In this case, the rectangular hyperbola and the log dose-response curves are likely to appear to be distorted, depending on the different rate constants present and the stochastic noise of the system. Nonlinear Scatchard plots are often seen, providing evidence of more complex binding relationships. A binding site with lower affinity (larger  $K_D$ ) will only be seen with higher concentrations, and, since the  $K_D$  is larger, the slope ( $-1/K_D$ ) will be flatter. Taken together, these data lead to a Scatchard plot that is concave upwards to the left. With enough data points, it is sometimes possible to resolve the curvilinear results into two straight lines, thus establishing  $K_D$  and  $B_{\text{max}}$  for each of the two receptor populations.

Other cases include multivalent receptors that bind two (or more) ligand molecules per receptor. Again, curvilinear Scatchard plots are obtained. In this case, however, binding of the second ligand occurs as a second-order delay and binding of the first ligand may change the shape of the receptor complex, thus altering the affinity of the second ligand molecule. This interaction between subsequent ligands is known as cooperative binding—negative if the second ligand exhibits lower affinity and positive if the second ligand exhibits higher affinity. Scatchard plots will appear concave upwards or downwards, respectively.

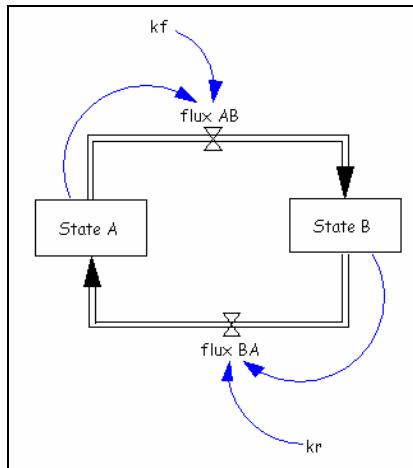
### 3. Application of SD to receptor dynamics

#### 3.1. Application of SD to simple 2SE processes

Because of the ubiquity of two-state equilibrium (2SE) processes in biological systems, we believe that a solid understanding of basic 2SE dynamics might help researchers to improve the design and interpretation of laboratory experiments involving cellular processes. SD is easily and naturally applied to the study of multi-state equilibrium processes. The researcher/modeler specifies aggregate state variables to represent the amount or concentration of both unbound and bound receptors, with the flux from unbound to bound and from bound to unbound represented as unidirectional flows (rates of change). Figure 2 illustrates the generic structure of a simple 2SE model. This model assumes that material is conserved:  $\{A\}_t + \{B\}_t = 1$  (or 100%) for all t.

We implemented the simple 2SE model using one of the popular SD packages, STELLA [20], and created a user interface to facilitate experimentation

with the model. Although we were already quite familiar with 2SE processes, the activity



**Figure 2. Generic 2SE model**

of constructing and experimenting with these admittedly very simple SD models was invaluable—forcing us to clarify our understanding of the underlying phenomena, which in turn enhanced our ability to infer what “should” happen under different circumstances.

It is relatively easy to add additional states and additional reaction processes to an SD model in order to model such phenomena as the interaction of agonists and antagonists, the opening and closing of ligand-gated ion channels, initial binding events that trigger a sequence of reactions (as in the case of second-messenger cascades), or divalent receptors that exhibit positive and negative cooperative binding.

### 3.2. Application of SD to insulin receptor dynamics

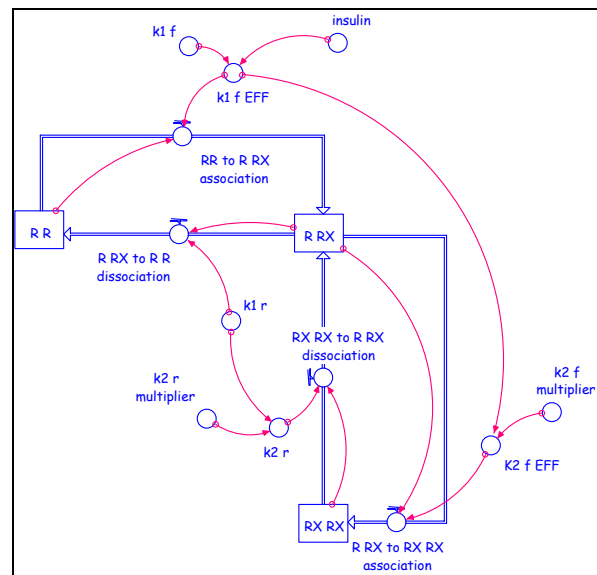
We implemented the divalent insulin receptor model described by Wanant and Quon [13] using STELLA. This is a 3SE system, with three state variables used to represent the three possible receptor states: unbound, singly bound with one insulin molecule, and doubly bound with two insulin molecules. Receptor-ligand binding kinetics of the first insulin molecule are represented by a bimolecular reaction where the first-order rate constant of association is  $k1\_f$  and dissociation is  $k1\_r$ . In order to represent the availability of the two binding sites on the divalent receptor, the forward rate constant,  $k1\_f$ , is multiplied by two. Because the forward rate constant is dependent on ligand concentration, there is an effective rate of association,  $k1\_f\_EFF$ , which is the product of ligand and receptor concentrations.

After the binding of the first ligand, the divalent receptor model assumes that a second ligand may bind to the same receptor. The first-order rate constant of association for the second ligand is  $k2\_f$ . Because only one binding site on this receptor is available,  $k2\_f$  is not doubled. The effective rate of this constant,  $k2\_f\_EFF$ , is the product of ligand concentration and the concentration of available singly bound receptors. The dissociation constant for the doubly bound ligand is  $k2\_r$ .

Parameter values for the simulation runs corresponded to the values used by Wanant and Quon. Receptor concentration was kept constant at  $1 \times 10^{-10}$  M. The range of insulin concentration was  $1 \times 10^{-14}$  to  $1 \times 10^{-6}$  M. Insulin concentrations were varied in a fashion similar to the way experiments are performed in the laboratory. The data from these simulation runs were used to generate Scatchard plots in order to verify that the SD model generates data comparable to the differential equation models used by Wanant and Quon.

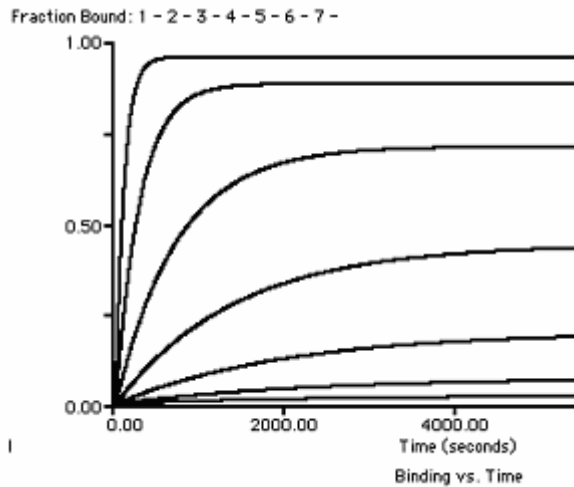
The default values for forward and reverse rate constants were also those chosen by Wanant and Quon. The range of values was consistent with published values,  $3 \times 10^5$  to  $4 \times 10^6 \text{ M}^{-1} \text{ s}^{-1}$  for  $k1\_f$  and  $1 \times 10^{-4}$  to  $1 \times 10^{-3} \text{ s}^{-1}$  for  $k1\_r$ . Based on the results of Pang and Shafer (1984) and DeMeyts, et al (1976), as reported by Wanant and Quon [13],  $k2\_r = 100 * k1\_r$ .

We first implemented the divalent insulin receptor model in STELLA. Figure 3 shows the STELLA version. Rate constants are defined as described above. By adjusting the rate constants  $k1\_f$ ,  $k1\_r$ ,  $k2\_f$ , and  $k2\_r$ , one can simulate both positive or negative cooperative binding.



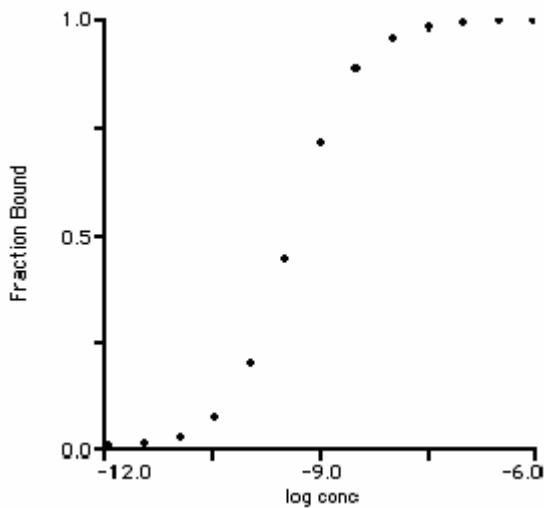
**FIGURE 3. Divalent insulin receptor model in STELLA**

Figure 4 illustrates the binding of radioactive ligand to a monovalent receptor (simulated by setting  $k_{2\_f}$  to zero). Each trace on the graph represents a different ligand concentration in the simulated incubation tube. This is done using automated sensitivity analysis. With increasing ligand concentration, the receptor is progressively saturated. In addition, the equilibration time decreases with increasing dose because of the increase in  $k_{1\_f\_EFF}$ .



**Figure 4. Fraction bound over time with different ligand concentrations**

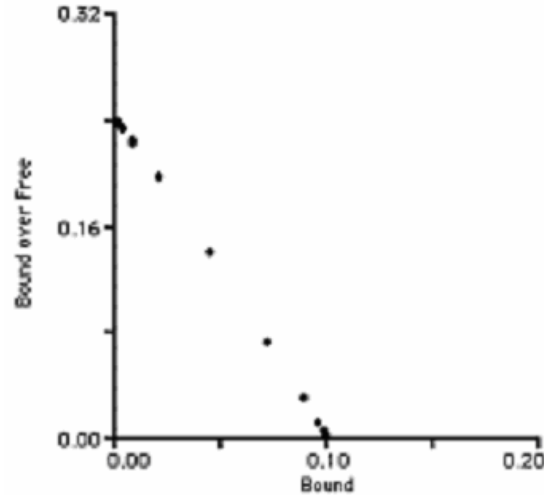
Figure 5 shows a log dose-response curve produced by the STELLA model. The smooth sigmoid curve suggests the presence of a single receptor population. Producing this type of graph in STELLA required the use of comparative x-y graphs and special logic to suppress most of the trace so that only the endpoint of each comparative run shows.



**Figure 5. Log dose-response curve**

Figure 6 provides a Scatchard plot. The fact that it is linear is also indicative of a single receptor population.

The x-intercept indicates the concentration of receptor, in this case  $1e-10$  moles/liter. The slope



**Figure 6. Scatchard plot from SD model**

indicates  $-1/K_D$ , which identifies the half-maximal binding concentration.

### 3.3. Summary

The results from the SD model match the data presented in the literature, and SD modeling appears to be an excellent fit for the analysis of multi-state equilibrium processes. We also determined that the software is able to create the types of plots and charts used by biomedical researchers. By building SD models and understanding their structural properties, and through experimentation with widely varying parameter values, the researcher would be able to significantly enhance their intuition regarding the underlying biological processes, and thereby enhance their ability to design and interpret laboratory experiments and experimental data.

## 4. Application of ABS to receptor dynamics

For our comparison, we selected StarLogo, an introductory two-dimensional ABS package that may be downloaded from MIT [11]. Originally developed for educational use, it has more than enough capability to model multi-state receptor dynamics.

One approach for doing so is to treat the background grid of spatial locations as a portion of the cell surface. In StarLogo, each grid location is called a patch. A small percentage of these patches (identified by their x-y coordinates on the grid) are specified to be receptor sites. The initial state of these receptors is either bound (with a molecule) or unbound. The molecules are modeled as agents. In ABS models, the motion of agents typically has a random component. In the receptor example, the motion is purely random (i.e., Brownian motion). As time proceeds in the

simulation, the molecules (agents) come into contact with the receptors. Upon contact, the molecules sometimes bind to the receptor, with a binding probability near zero. Given sufficient time, however, bindings do occur. Once bound, receptors unbind with a particular probability, freeing up the previously bound molecule.

If two different types of ligand molecules are present, such as agonists and antagonists, the receptor could be in one of three states (unbound, bound to agonist, and bound to antagonist), so it would be a type of 3SE model, but different from the 3SE model discussed in Section 3.2 where there is only one type of ligand molecule, but the receptor is divalent.

In ABS, The binding logic is implemented as a small computer program. Other programs establish initial conditions and carry out other administrative functions. As model complexity increases, more programs are written. The divalent receptor, for example, would be implemented with the addition of a doubly bound state for the receptor, plus additional functions to represent the transition to and from the doubly bound state. Similar additions could account

for channel opening and closing, and other complex processes.

In StarLogo, the user interacts with the model using various controls such as buttons and sliders. For example, a <setup> button might be used to establish the initial conditions, and a <go> button might be used to cause the model to run. Various “sliders” are used to set the values of parameters, such as the number of receptors, constants used to determine the probability of binding and unbinding, etc. When a model is run, icons representing the different types of agents (molecules and/or receptors) appear on the screen, moving around and/or changing state (based on their logic). The state of an agent is represented by its color and/or the shape of its icon. For example, when a molecule contacts a receptor, it may bind to it, which could be represented by the receptor changing color or shape. Over time, the receptors might eventually change back to their original color or shape, signifying that the molecule has unbound from the receptor. Figure 7 shows the Starlogo user interface from our model.

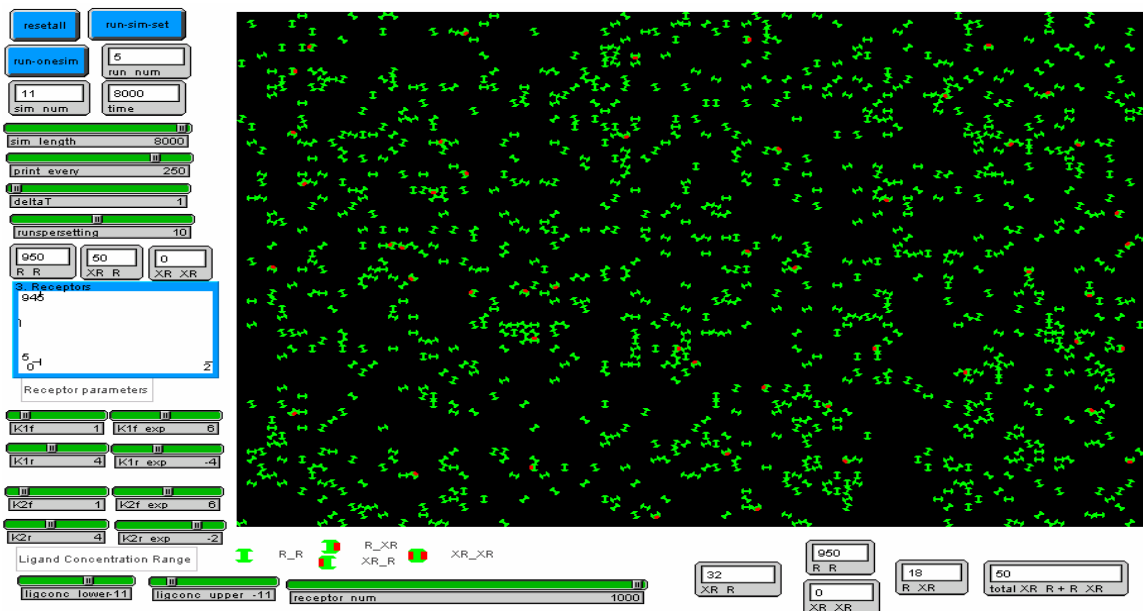


Figure 7. StarLogo model interface

The number of agents over time that meet various criteria may be plotted, and, with a few lines of programming, data regarding the number of bound and unbound molecules over time may be saved to a file for subsequent analysis using Excel or a statistical analysis package. It is also relatively easy to program StarLogo to conduct a set of experiments wherein the model is run repeatedly, with parameters being varied in a systematic fashion. An experiment might consist

of a single model run or several runs with the same parameter values but with different random numbers.

#### 4.1. Application of ABS to simple 2SE processes

We first programmed the simple 2SE model with the receptors represented as patches and the molecules represented as agents. We graphed the number of bound and unbound receptors over time. We were mesmerized by the visual effects of the “molecules” dancing about, binding to the receptors, the receptors

changing color and then reverting back. We adjusted the probabilities dynamically and “experienced” the equilibrium point shift (through the changing colors on the screen), either quickly or slowly, and either to a large degree or to a lesser degree, depending on how the parameters were changed.

We imagined what it would be like to connect the model to a planetarium-like projector that would fill an entire hemisphere with tens of thousands of receptors and millions of molecules; the observer would seem to be inside a cell looking outwards toward the cell surface watching the biochemistry at work on the surface. We viewed the plots with different parameter values and were intrigued by the random effects superimposed on the essentially mono-exponential graphs.

#### 4.2. Application of ABS to Insulin Receptor Dynamics

Initially we thought we would continue to model the receptors as coordinates on the x-y grid (patches in StarLogo), but we soon realized that it is computationally more efficient to model the receptors as agents, even though we did not anticipate having them move. Our initial divalent insulin model used agents to model both ligand molecules and receptors.

Although watching the molecules move around and sometimes bind to a receptor “felt right,” as we began to run experiments, we quickly realized that in order for the model to even remotely resemble biological reality, we would need to have at least  $10^3$  receptors. With realistic binding probabilities, the number of ligand (insulin) molecules would need to be several orders of magnitude higher, which is not possible in StarLogo. We were stymied until one of the authors said, “I’ve been pondering our dilemma, and I don’t think we really need the molecules!” It sounded like heresy! But they were right. All we needed to model was the probability of a receptor binding in a given time period. The model ran dramatically faster.

In order to reproduce the binding experiments, we wrote logic to execute a sequence of runs with varying ligand concentrations. We provided sliders to set the lower and upper ligand concentration. The model determined how many runs were needed, at four values per decade, on a log scale. We began running experiments and quickly realized that at lower concentrations the model needed to run much longer to reach equilibrium and that there was considerable variance in the ending number of bound ligand molecules from one run to the next. The total number of bound ligand molecules is the number of singly bound receptors plus two times the number of doubly bound receptors. These are the numbers typically

obtained from the binding studies using radioactive ligands. Making the necessary runs took many hours in StarLogo. We tried using a time interval  $\Delta T$  greater than 1 second in order to shorten the run time. In these runs, the probability was multiplied by  $\Delta T$ , and time was advanced each iteration by  $\Delta T$  instead of 1. With a  $\Delta T$  of 10, the runs were 10 times faster, but due to the variance in the ending number of bound receptors, we were not confident that we had accurately determined the asymptote. At the lowest concentration, we knew that the theoretical value was 50, but we obtained values from 33 to 65. We instrumented the model to make multiple runs with the same parameter values. We spent countless hours making multiple runs in order to assure ourselves that the results were due to inherent randomness and not model errors.

Table 1 provides sample lab notes from these runs. Note that the reaction rate parameters are integers. This is because StarLogo provides integer valued random numbers rather than Uniform[0,1] random numbers. We began by expressing the reaction probabilities as numbers between 0 and 1000, but soon realized we needed to increase the upper limit. In Runs A, B, and C we used 0 to 100000, and by Runs D and E we had converted the model to express them as numbers between 0 and 1000000. The decisive run (not shown in Table 1) was for 40000 seconds (five times longer than what we had thought was necessary) using a  $\Delta T$  of 1 second. The data from this run showed an approximate asymptote of 50 with considerable variance, increasing our confidence in the model.

A separate issue was that at higher concentrations equilibrium came quickly. We reduced the print interval and shortened the run times, since the longer runs necessary at lower concentrations were superfluous. Overall, considerable “babysitting” was required during the experimental runs, to adjust the run length and because StarLogo simply stopped

**Table 1. Lab notes regarding multiple model runs at low concentrations**

Concentration	Final # Bound				
	Run A	Run B	Run C	Run D	Run E
1.00E-11	33	48	65	37	39
1.78E-11	49	71	87	87	91
3.16E-11	125	133	127	n/a	131
5.62E-11	178	213	237	n/a	238
1.00E-10	287	316	321	n/a	305
<b>Parameters</b>					
Run Length	4000	8000	8000	8000	8000
K1f	2	10	2	20	20
K1r	40	200	40	400	400
K2f	1	5	1	10	10

K2r	8000	40000	8000	80000	80000
DeltaT	1	5	1	1	1
Prob=1	10 <sup>5</sup>	10 <sup>5</sup>	10 <sup>5</sup>	10 <sup>6</sup>	10 <sup>6</sup>

running from time to time for no reason we could determine. Figure 7 shows the final StarLogo model and Table 2 shows a selection of the model logic.

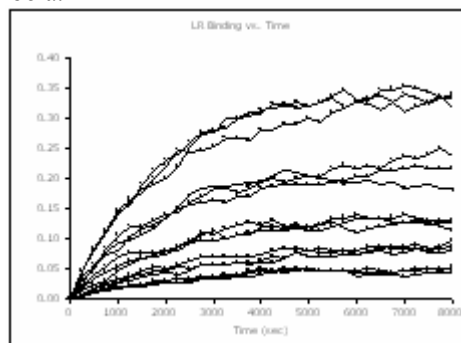
**Table 2. StarLogo code fragments from the divalent insulin receptor model**

<pre> setsim_num 0 setligconc (10 ^ ligconc_lower) calc-keffs setnumber_sims 4 * (ligconc_upper - ligconc_lower) + 1 repeat number_sims [   setsim_num sim_num + 1   setrun_num 0   repeat runspersetting   [     setrun_num run_num + 1     run-sim   ]   setligconc ligconc * (10 ^ .25)   calc-keffs </pre>	<p>An illustrative segment of the control logic for running experiments, potentially multiple times for a given ligand concentration</p>
<pre> to calc-keffs   setK1f_eff1000000 1000000 * 2 * ligconc   * K1f * (10 ^ K1f_exp) * deltaT   setK2f_eff1000000 1000000 * ligconc *   K2f * (10 ^ K2f_exp) * deltaT   setK1r1000000 1000000 * K1r * (10 ^   K1r_exp) * deltaT   setK2r1000000 1000000 * 2 * K2r * (10 ^   K2r_exp) * deltaT </pre>	<p>Logic to calculate the reaction constants for a given ligand concentration</p>
<pre> To check-bind if (state = unbound) [   if (random 1000000) &lt; K1f_eff1000000   [     ifelse ((random 100) &lt; 50)     [setshape shape-R_XR]     [setshape shape-XR_R]   ]   setstate bound   setstate_num -1 </pre>	<p>A fragment of an agent procedure that determines if binding will occur, and if so, what happens</p>

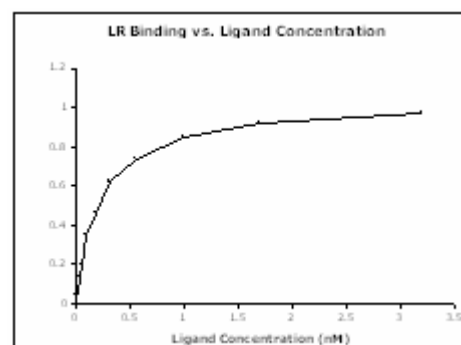
Figures 8-11 were created using Excel from the data collected during the many experiments that we ran. Data from the StarLogo runs was written to the output window in a tab-delimited format to allow quick and easy transfer to Excel.

Figure 8 shows simulations of insulin binding to the high-affinity site of the divalent insulin receptor. Insulin concentrations were held constant at 1e-11, 1.7e-11, 3.2e-11, 5.6e-11, and 1e-10 nM. These concentrations saturate about 50% of the receptor sites. Three simulations were conducted at each concentration, showing the stochastic variability observed, even with just 1000 receptors in the model. The observed variability decreases considerably with larger numbers of receptors, but at the cost of a significant increase in simulation times.

Figure 9 shows receptor saturation vs. ligand concentration, yielding the expected rectangular hyperbola.

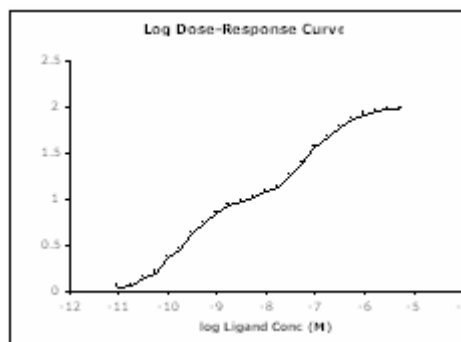


**Figure 8. Ligand-receptor binding vs. time**



**Figure 9. LR binding vs. ligand concentration**

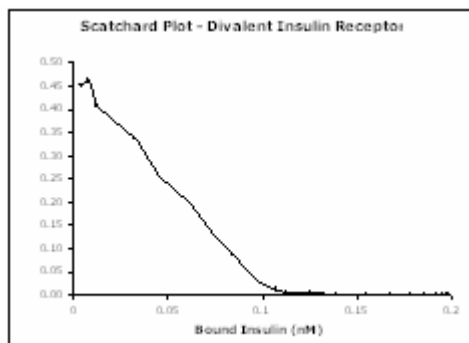
Figure 10 illustrates the sigmoidal dose-response curve. With simple monovalent receptors, a single sigmoidal curve would be expected in the lower left graph. In this case, however, the lower left portion of the curve shows the ligand approaching saturation of the first (high-affinity) site (density = 1 ligand per receptor). As the concentration rises further, the second (low-affinity) site begins to bind, ultimately saturating the receptor with two ligand molecules per receptor.



**Figure 10. Log dose-response curve**

Figure 11 is a Scatchard plot of the data shown in Figure 10. The linear portion of the curve to the left is

due to the high-affinity site; the slope =  $-1/K_D$  (affinity), and the x-intercept indicates  $B_{max}$ , or the density of receptors. In this simulation,  $B_{max}$  is 0.1 nM/liter, as described in Wanant and Quon [13]. The Scatchard plot is concave upwards to the left, indicating the presence of a second, low-affinity binding site in the incubation tube. Further laboratory experiments would be required to determine if the concavity is due to a single divalent receptor population or two separate receptor populations with different binding characteristics.



**Figure 11. Scatchard plot, divalent insulin receptor**

#### 4.3. Summary

Visualization and the ability to vary aspects of the simulation dynamically are excellent in ABS. It is easy to communicate simulation results to others by having them observe the simulation. By watching the motion and color changes of agents and observing graphs over time regarding the number of various types of agents present, both students and researchers can gain insights into the functioning of cellular receptors. In addition to seeing the receptors bind and unbind, observers can see the variability in the runs with low ligand concentration, an aspect of realism that is not apparent with SD models.

The rules governing behavior are embedded in computer programs, which might tend to make the models less accessible. However, the logic is in fact rather simple and quite easy to read and comprehend. With adequate documentation of the program, an individual with little or no programming experience can understand the functions of the various subprograms. Thus, ABS is a good candidate for collaborative work between individuals with specialized knowledge about a given phenomenon and individuals with programming skills.

We also found some limitations when using StarLogo for this type of research. Due to the slow execution speed, we often had to “baby-sit” the simulation runs, customizing the run parameters for each run in order to gain efficiency. When we tried to make long unattended runs, we found that for no

apparent reason StarLogo often stopped running after an indeterminate number of hours.

Nevertheless, we found that ABS can help provide insights into receptor binding that are difficult, if not impossible, to derive from SD models alone.

### 5. Overall Comparison of SD and ABS for Studying Receptor Dynamics

System dynamics models portray the *structure* of the interrelationships between variables very effectively and allow the user to easily experiment with different parameter values and compare the resulting graphs of behavior over time. SD models may be considered more conceptually descriptive than ABS models, and they force the modeler to consider carefully the appropriate level of aggregation. STELLA is easy to use and highly “approachable.” However, sensitivity testing with non-trivial STELLA models is very time consuming (although orders of magnitude faster than with StarLogo).

The agent-based simulation paradigm forces the modeler to consider carefully the definition of agents and to specify their behavioral rules in the simplest possible fashion. ABS models are spatial and are able to easily portray interactions at the cellular/molecular level. This allows the model to reflect, among other things, the random way in which molecules bind and unbind with receptors. Thus, ABS is ideally suited for studying problems when the probability of interaction is low and the stochastic aspects of the process are important.

We found the process of developing and testing models using two very different paradigms to be incredibly useful. We believe that both paradigms could be productively used to help educate biomedical researchers and assist with laboratory research. Conducting dynamic experiments on the computer and observing simulations unfolding on the screen greatly enhances awareness of the interesting underlying dynamics. We believe that this enhanced awareness would lead to the design of better laboratory experiments in this important area of research. SD might be a more appropriate research tool, but ABS models may be better suited for educational purposes. Although a scientist doing advanced research on receptor dynamics might prefer SD models, a student or researcher still learning about receptor dynamics might benefit by first creating ABS models. Researchers who use either of these paradigms are more likely to design laboratory experiments that fully characterize the time dynamics of the processes being studied.

We conclude with a comparison of SD and ABS in terms of overall approach, mathematics, ease of

communications, research relevance, and educational potential (Table 3).

**Table 3. Comparison of SD and ABS**

	<b>System Dynamics (STELLA)</b>	<b>Agent Based Simulation (StarLogo)</b>
<b>Overall approach</b>	Abstract, via state variables and equations that are solved to simulate behavior over time	Physical emulation of “agents” whose rules for behavior mirror the real world
<b>Mathematics</b>	Calculus; numerical integration of difference equations	Logic, algorithms, and simple probabilities
<b>Ease of communications</b>	Very good for showing model structure and numerical results	Excellent for showing the behavior of individual entities
<b>Biomedical research relevance</b>	Appropriate for modeling the aggregate behavior resulting from interactions between multiple types of material. However, the reliance on variables that lump together all of the material of a particular type makes it difficult to address unique behavior and dynamics at the entity level and to show how the aggregate behavior might <i>emerge</i> . Its use in biomedical research is likely to increase as the software becomes increasingly user friendly and is further adapted for biomedical applications	Appropriate for modeling movement and state changes of individual entities, and the interactions between such entities; but inefficient at modeling very large numbers of interacting entities. The process of running experiments on the computer closely resembles the actual experimental process, which significantly increases its relevance for research
<b>Educational potential</b>	Particularly useful for increasing conceptual understanding, especially regarding the very powerful and general methodology of compartmental analysis	Very useful, due to the way it mimics the actual physiological processes and also, potentially, the experimental procedures employed in the laboratory

## References

- [1] H.J. Scholl, “Agent-Based and System Dynamics Modeling: A Call for Cross Study and Joint Research”, *Proceedings of the 34<sup>th</sup> Hawaii International Conference on System Sciences: 1-8*, 2001.
- [2] J.D. Sterman, *Business Dynamics: Systems Thinking and Modeling for a Complex World*, Irwin-McGraw Hill, Boston, 2000.
- [3] A.M. Law and W.D. Kelton, *Simulation Modeling and Analysis: 3<sup>rd</sup> Edition*, McGraw-Hill, 2000.
- [4] N. Gilbert and S. Bankes, “Platforms and Methods for Agent-Based Modeling”, *Proceedings of the National Academy of Science*, 99 Suppl. 3, 2002, pp. 7197-7198.
- [5] M. Hashimoto and K. Tokkuda, “Computer Simulation Study of Intracranial Hemodynamics and ICP Wave Form”, *Intracranial Pressure IX*, eds. H. Nagai, K. Kamiya, and S. Ishii, Springer-Verlag, Tokyo, 1994, pp. 480-481.
- [6] B. Hsieh, Y. Chen, K. Wu, Y. Kuo, and P. Lee, “A Simulation Study on Rennin and Aldosterone Secretions in Aldosteronism”, *Journal of the Formosan Medical Association*, 89, 1990, pp. 346-349.
- [7] E.J. Gallaher, “Biological System Dynamics: from Personal Discovery to Universal Application”, *Simulation*, 66, 1996, pp. 243-257.
- [8] E.J. Gallaher, High Resolution Management of Post-Operative Pain with STELLA,” *Proceedings Medical Simulation Conference*, 1998, pp. 122-127.
- [9] S.C. Banks, “Agent-Based Modeling: A Revolution?”, *Proceedings of the National Academy of Sciences*, 99 Suppl. 3, 2002, pp. 7199-7200.
- [10] M. Resnick, *Turtles, Termites, and Traffic Jams: Explorations in Massively Parallel Microworlds*, MIT Press, 1994.
- [11] <http://www.media.mit.edu/starlogo>.
- [12] D.A. Lauffenburger and J.J. Linderman, *Receptors: Models for Binding, Trafficking, and Signaling*, Oxford University Press, 1993.
- [13] S. Wanant and M. Quon, “Insulin Receptor Binding Kinetics: Modeling and Simulation Studies”, *Journal of Theoretical Biology*, 205, 2000, pp. 355-364.
- [14] J.P. Mauger, F. Sladeczek, and J. Bockaert, “Characteristics and Metabolism of  $\alpha_1$  Adrenergic Receptors in a Nonfusing Muscle Cell Line”, *Journal of Biological Chemistry*, 257 (2), 1982, pp. 875-879.
- [15] P.R. Shepherd and B.B. Kahn, “Glucose Transporters and Insulin Action: Implications for Insulin Resistance and Diabetes Mellitus”, *New England Journal of Medicine*, 341(4), 1999, pp. 248-257.
- [16] L.E. Limbird, *Cell Surface Receptors: A Short Course and Methods*, Kluwer Academic, Boston, 1996.
- [17] V.W. Rodwell and P.J. Kennelly, “Enzymes: Regulation of Activity”, *Harper's Biochemistry*, eds. R.K. Murray, D.K. Granner, P.A. Mayes, and V.W. Rodwell, McGraw-Hill, New York, 2000, pp. 110-122.
- [18] W.B. Pratt, “The Entry, Distribution, and Elimination of Drugs”, *Principles of Drug Action*, eds. W.B. Pratt and P. Taylor, Churchill Livingstone, Philadelphia, 1990, pp. 201-296.
- [19] L.A. Bauer, *Applied Clinical Pharmacokinetics*, McGraw-Hill, New York, 2001.
- [20] <http://www.hps-inc.com>.